

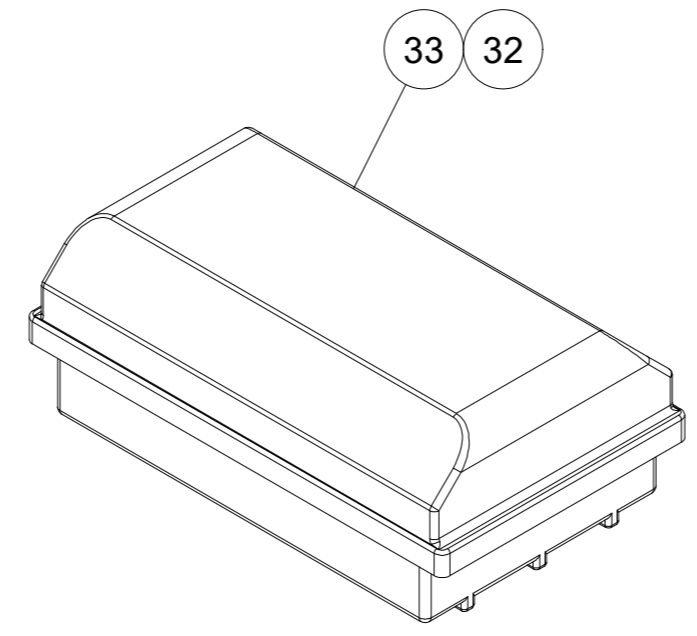

Revision History				
Rev	Revision note	Date	Rev no	Sign
G	Drawing view updated	2018-10-16	5511	joaed
H	Geometri changed to reached specified lift storke. Veivs updated.	2019-11-01	6731	LEIJO
J	Item 5. spacer, hardening added.	2022-05-05	9139	Leijo
K	Website view updated.	2022-08-08	9347	EliEd

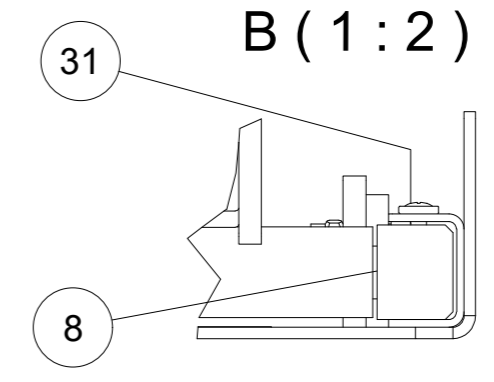
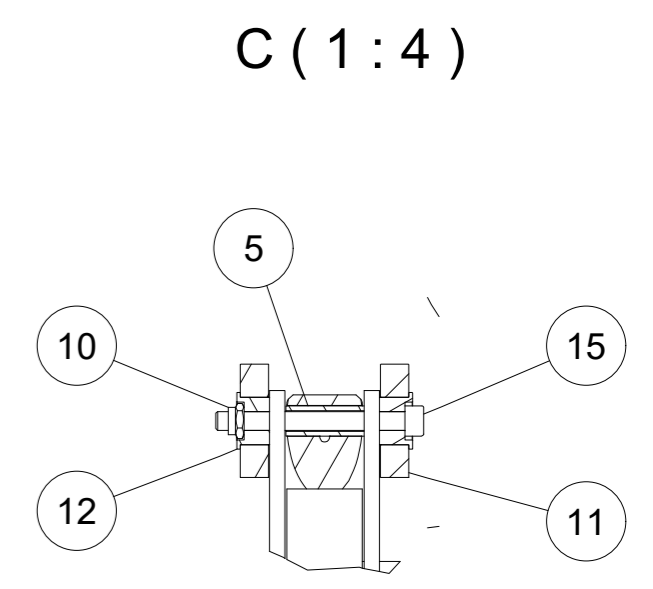
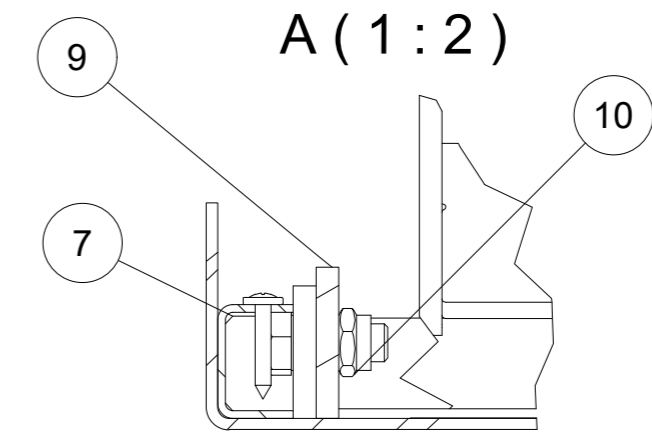
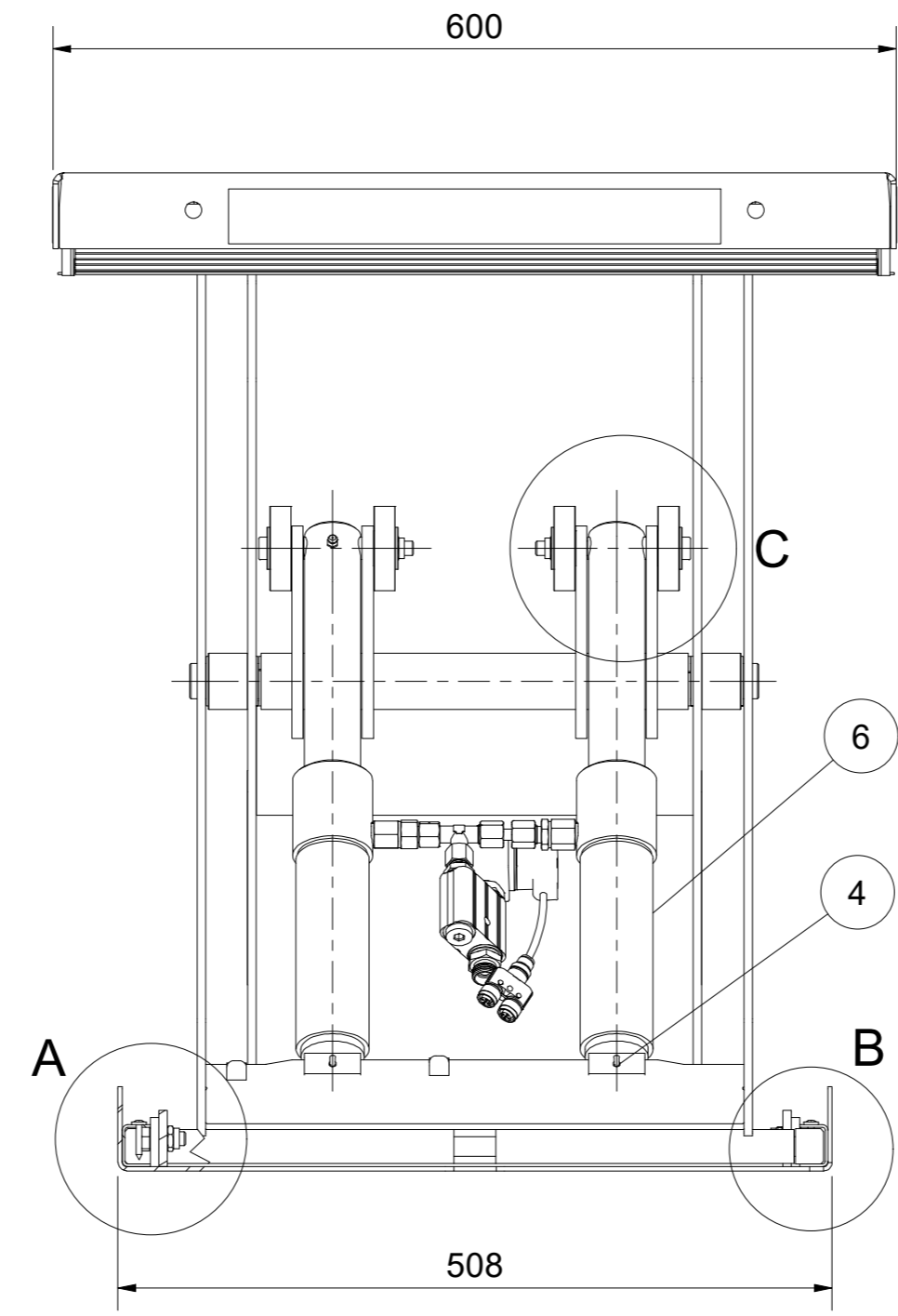
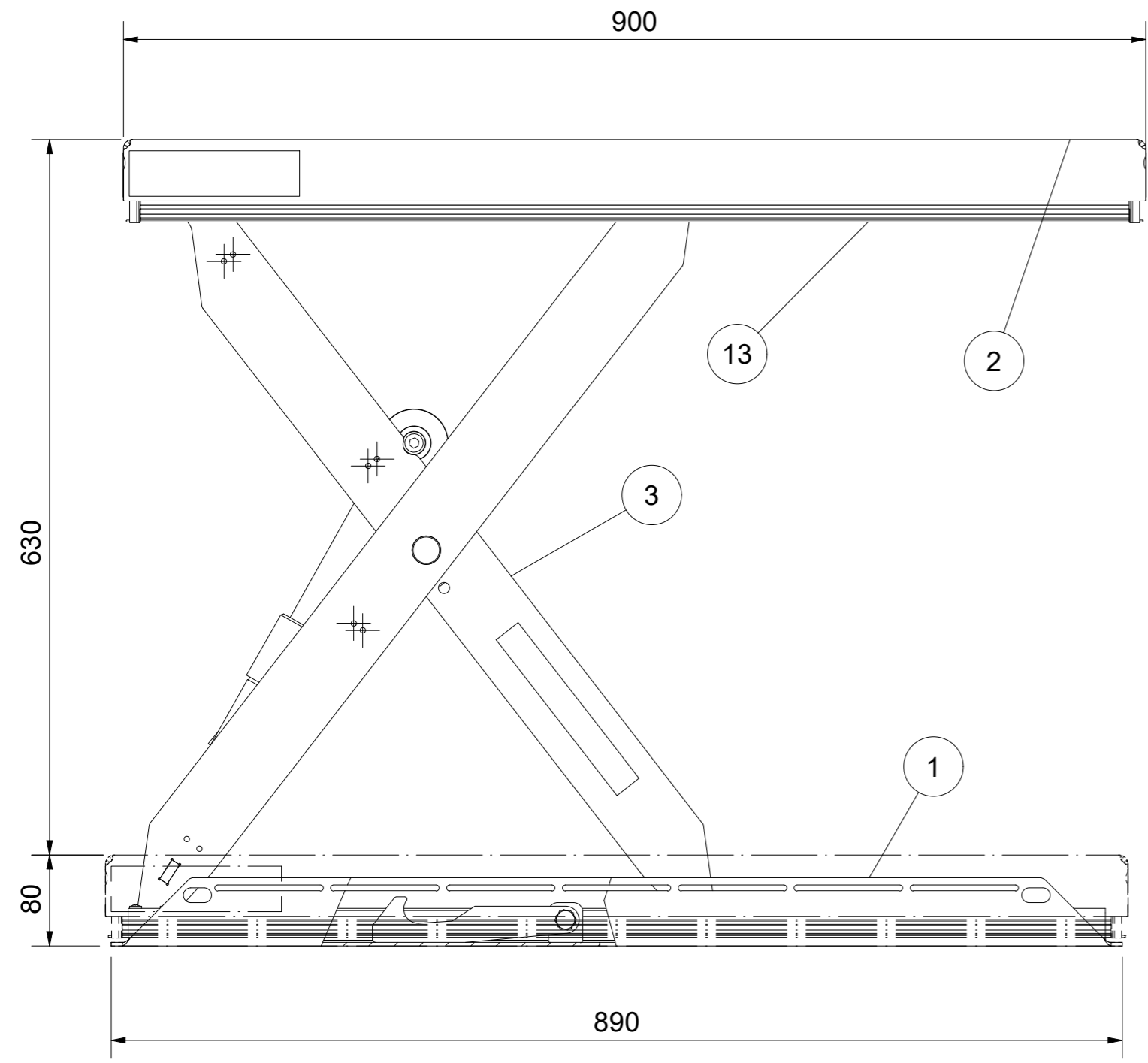

35	1	Decal	43998	Machine Nameplate
34	2	Clip	85690	
33	1	Remote PP, plastic cover	33121	
32	1	Hydraulic Power Pack H3-4 0,75 kW, UC60, VE25, 3-phase	612217	H3-4, 3-phase, 400V, 0,75kW, VE25
31	8	Screw	84879	4,2x25 FZB
30	1	M12 Y-distributor 5p	85946	
29	2	Decal	32707-05	Max. Load 500 kg
28	1	Plug M12M	85905	4-pol
27	1	Cable	36328-300	M12M-valve L=300 mm
26	1	Hydraulic pipe with fitting	612178	Ø8x1,5 L=41
25	1	Decal	33269	Language set at order
24	2	Decal	32708	Edmolift Logotype medium
23	2	Decal	84400	Load cases
22	1	Fitting	85879	EVGEO 8L G1/4"-ED
21	2	Washer Sealed	84233	G1/8" Tredo
20	1	Hydraulic valve VE14	34886-7	
19	1	Fitting	85876	EVTO 8L T-k
18	1	Fitting	85584	GE8L G1/4"-ED
17	2	Flow Control Fitting	513612	
16	1	Hydraulic Hose	516193-3000	HC 1/4" 1+1 L=3000
15	2	Screw	87287	MLC6S M10x100 8.8
14	4	Locknut	83207	LM6M M8 FZB
13	1	Safety Frame	35731	
12	4	Hub	44701	
11	4	Wheel	44700	
10	4	Locknut	83209	LM6M M10 FZB
9	2	Maintenance Bar	33508	
8	4	Slide Block	44718	
7	4	Slide Block	42207	40x25x20
6	2	Hydraulic Cylinder	34409	HC 40-175
5	2	Spacer	44224	Ø11/16x41,5
4	2	Cotter Pin	83205	SP 4x32 FZB
3	1	Scissor	34914	
2	1	Platform	34918	900x600
1	1	Base Frame	34916	

Lift Table		Drawn	ROBBE	Date	2011-01-20
GA		Scale	1:5	Est. weight	N/A
TCR 500 (900x600)		Sheet Number	1 / 3		
		General tolerances for dimensions without indication according to	System	Drawing no	Revision
		ISO 2768-m	Inventor	34919	K
			Sheet size		
			A2		

This document must not be copied without our written permission, and the contents thereof must not be imparted to a third party nor be used for any unauthorized purpose. Contravention will be prosecuted.

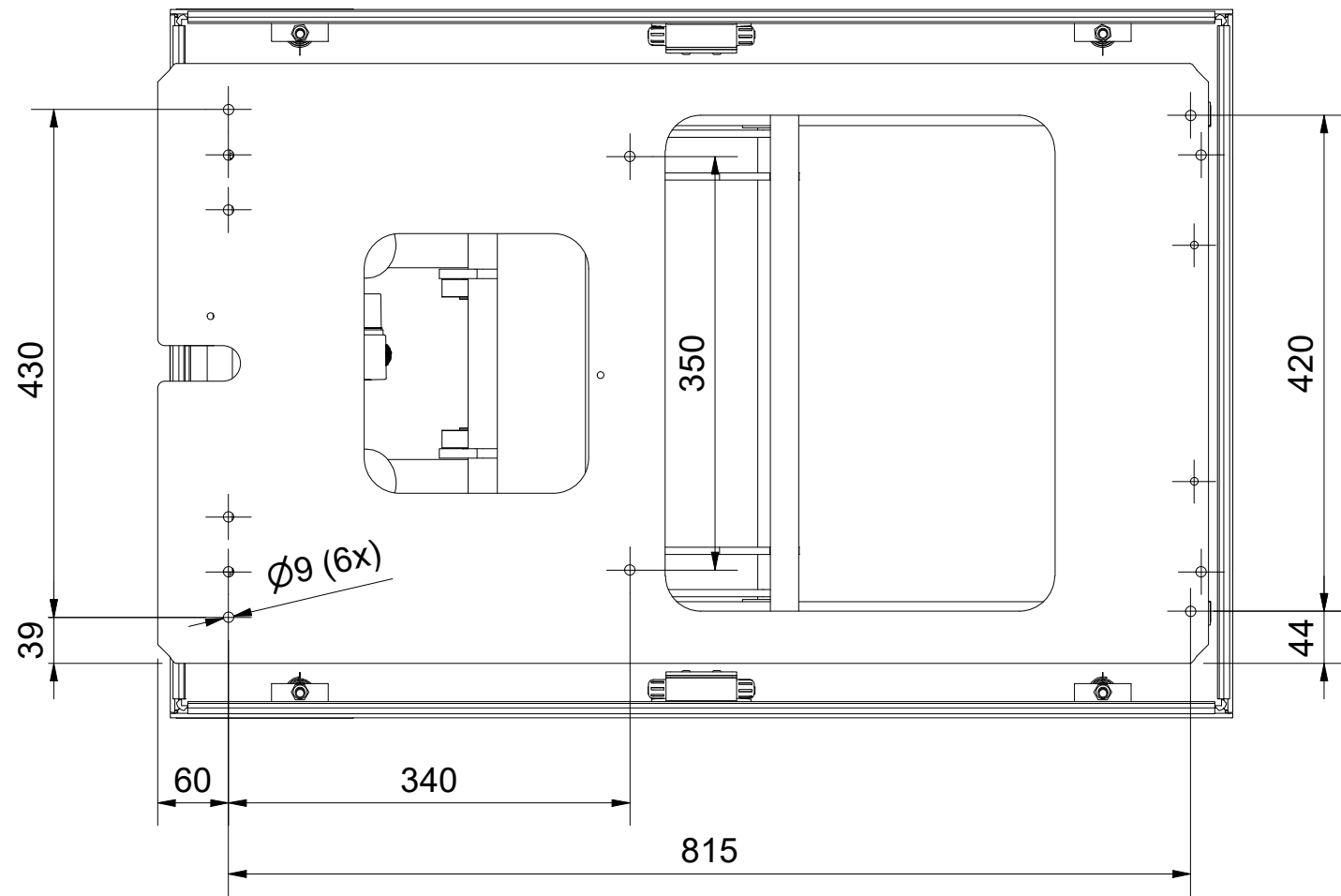

Recommended to use M8 (6x) to fix lift table to floor.

Maintenance ( 1 : 6 )

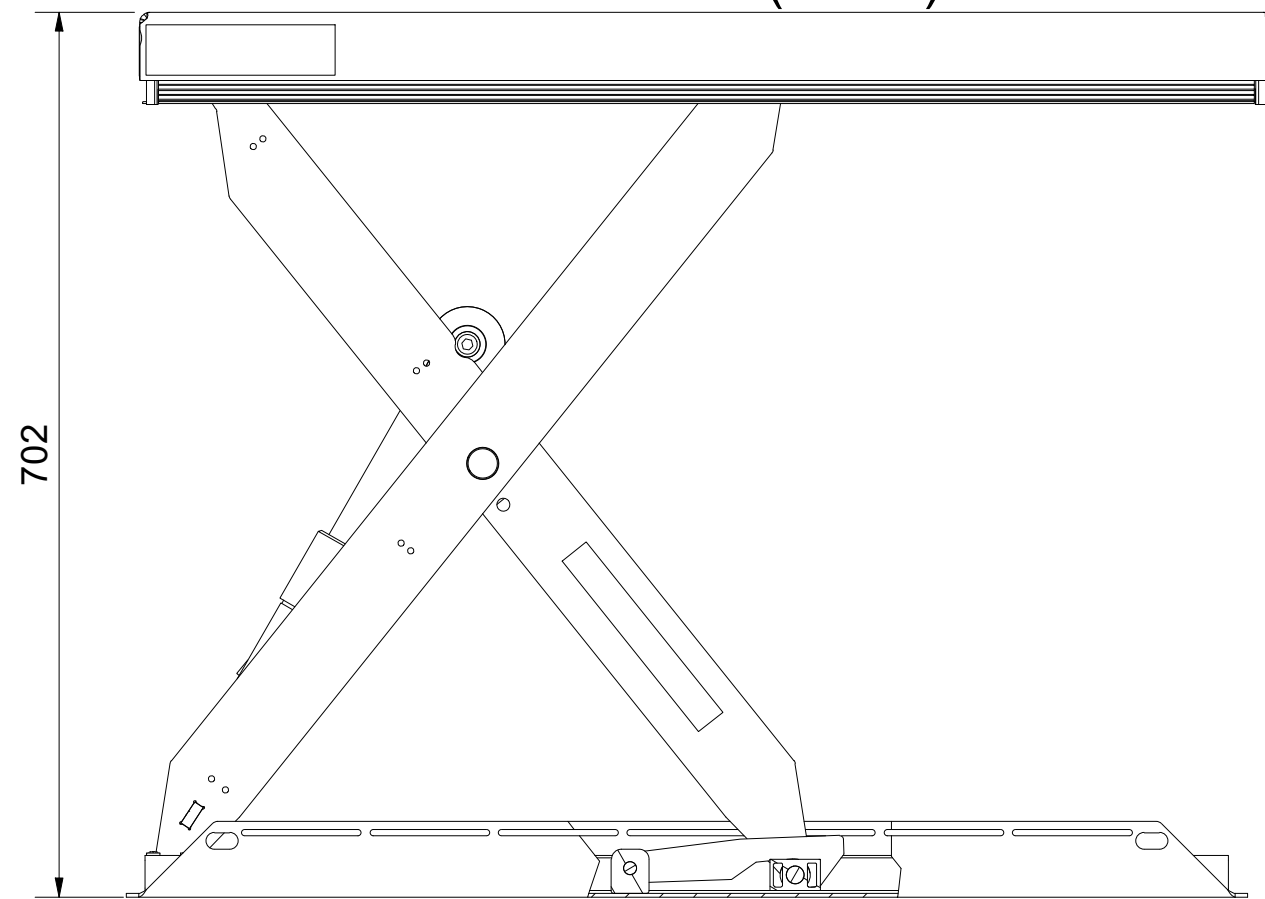

Lift Table GA TCR 500 (900x600)	Drawn	ROBBE	Date	2011-01-20
	Scale	1 : 5	Est. weight	N/A
	Sheet Number	2 / 3		
 <small>www.edmolift.se</small>	General tolerances for dimensions without indication according to	System	Drawing no	
	ISO 2768-m	Inventor	34919	
		Sheet size	Revision	
		A3	K	

This document must not be copied without our written permission, and the contents thereof must not be imparted to a third party nor be used for any unauthorized purpose. Contravention will be prosecuted.

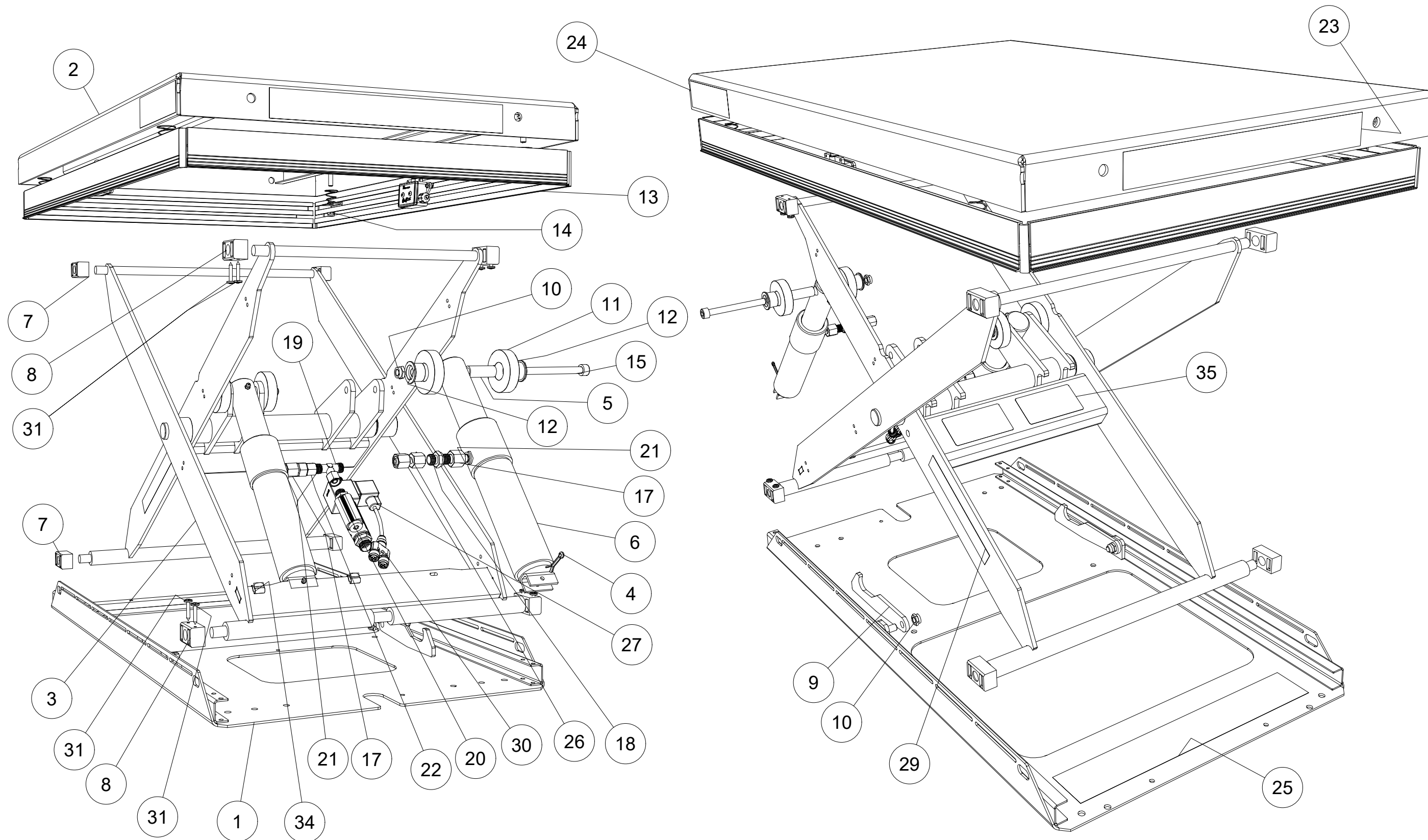

This document must not be copied without our written permission, and the contents thereof must not be imparted to a third party nor be used for any unauthorized purpose. Contravention will be prosecuted.

Lift Table GA TCR 500 (900x600)	Drawn <b>ROBBE</b>	Date 2011-01-20
	Scale 1 : 5	Est. weight N/A
	Sheet Number 3 / 3	
	General tolerances for dimensions without indication according to ISO 2768-m	System <b>Inventor</b> Sheet size A3
Drawing no <b>34919</b>		Revision <b>K</b>

This document must not be copied without our written permission, and the contents thereof must not be imparted to a third party nor be used for any unauthorized purpose. Contravention will be prosecuted.

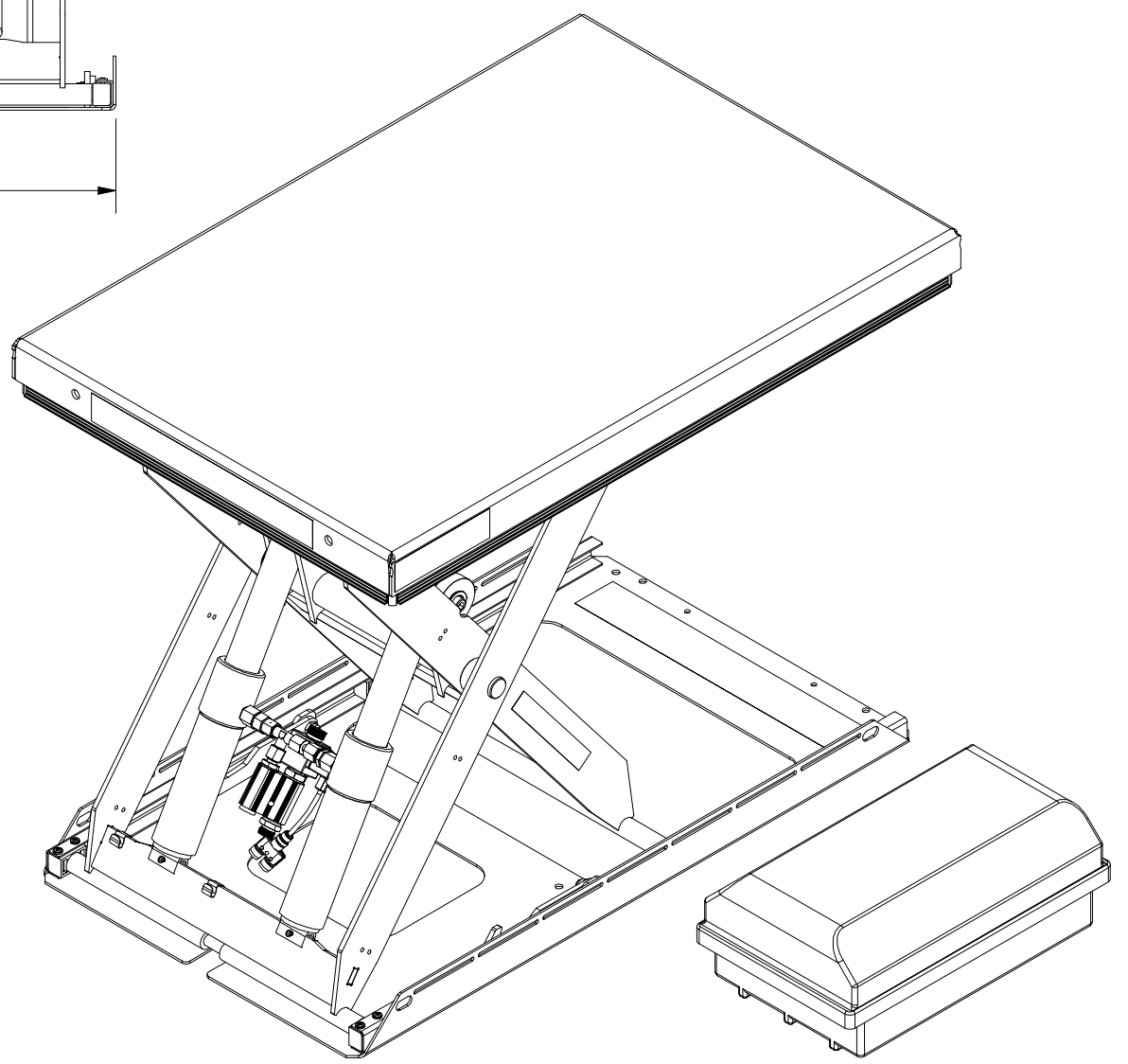
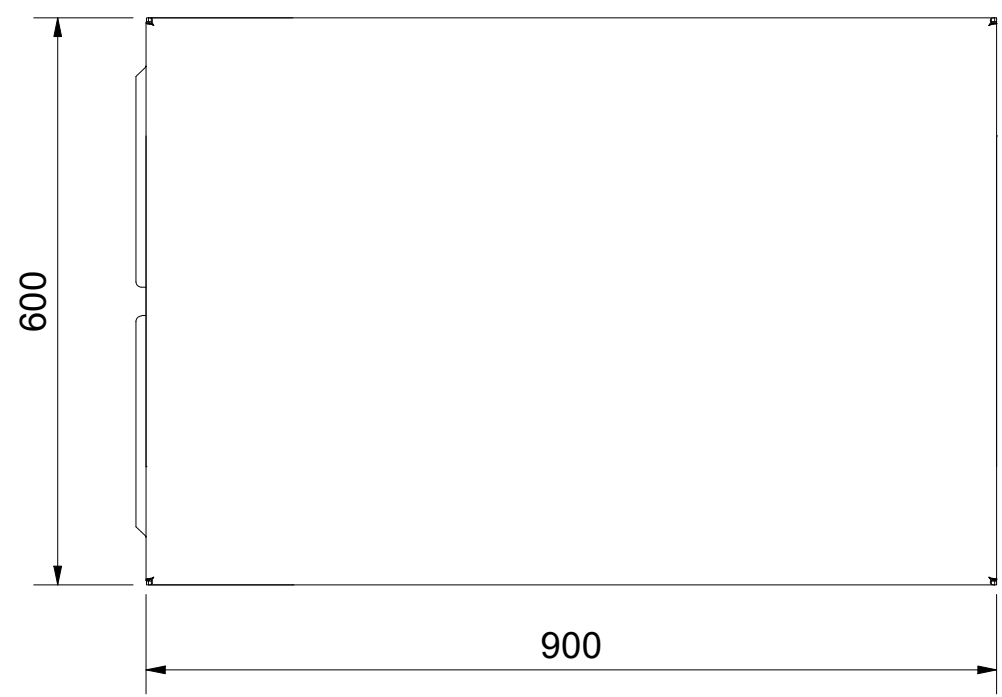
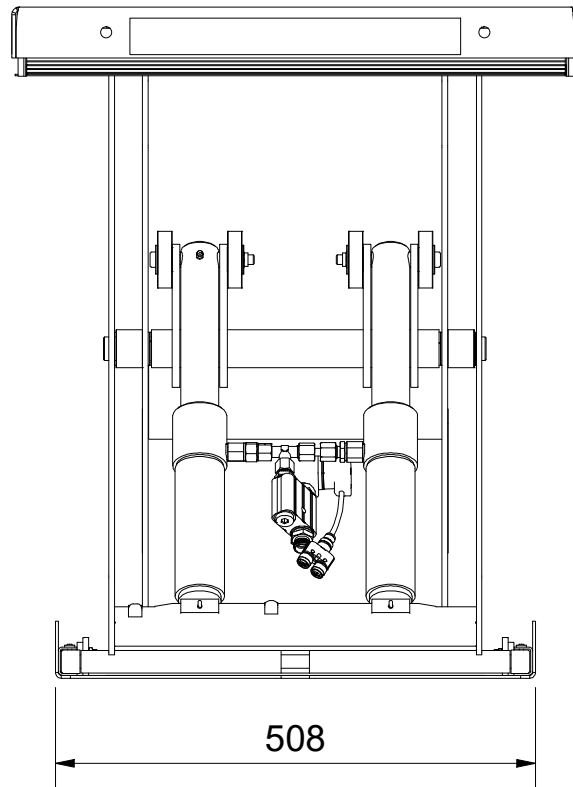
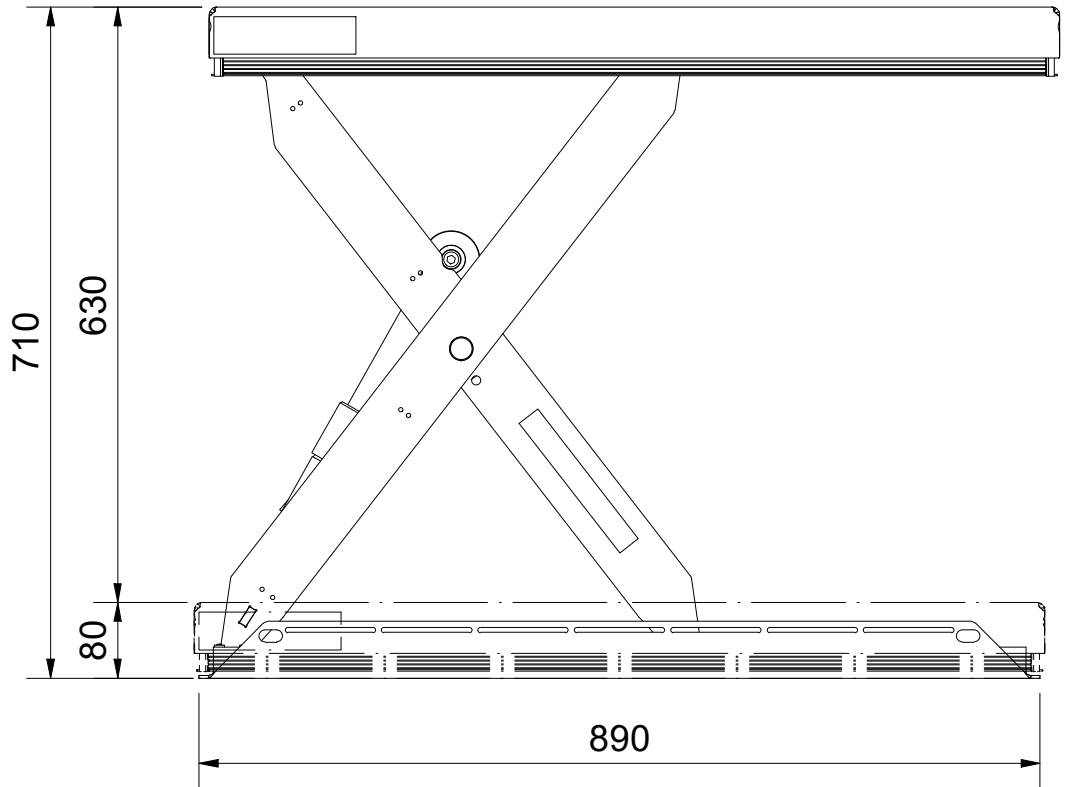

TCR 500 (900x600)  
www.edmolift.com

Drawing no  
**34919**